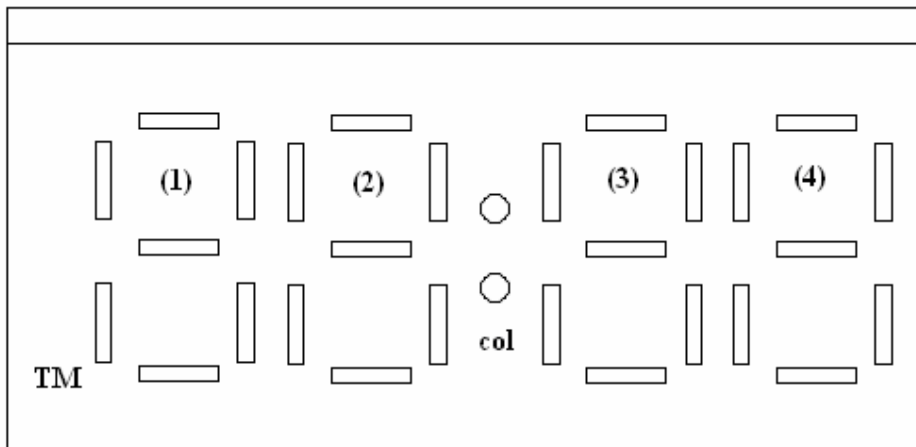

Timer**1. Features**

- 4 digit LCD display with two dots.
- Default Timer for Hour / Minute or Day / Hour by bonding option.
- 1 keys operation.
- 4 bonding option to select default timer value.
- Very low power consumption.
- 32768 Crystal oscillator.
- Single 1.5V operation.
- Direct drive 1/2 bias 1/3 duty LCD(Vop 3.0V).
- Alarm sound: The alarm sound continues for 60 seconds. It generates (4KHz x 4Hz x 1Hz) sound signal at first 60 seconds. The alarm sound will be stopped by pressing any key.
- Key tone : It will generate a sound signal (tone) when start/stop key is pressed.
- Power on : All LCD segments and the alarm sound are turned on for two second.

**LCD Drawing**

**Operation Flow**

- (a) After the power on, it return to display shows “Default timer value”, “colon” and “TM” always on (not flash).
- (b) Countdown Timer: This timer fixed timing count down. The step is one minute or one day (selectable by bonding option) . Press “Start/Stop” key to start counting. The “TM” always on. The “colon” 0.5 second on and 0.5 second off at counting, no flash at stop The alarm sound generates when the timer reached zero, press “Start/Stop” key to stop counting even the timer in counting or reached zero, press the key again then return to continues counting.
- (c) Press “Start/Stop” and hold it for 2 second, the timer will reload “Default timer value” and stand-by for start counting.
- (d) Keys: Only “ST/SP” key for start, stop and repeat.

**Pin Assignment**

<b>DESIGNATION</b>	<b>TYPE</b>	<b>DESCRIPTION</b>
B0, B1	OUTPUT	Buzzer output
V1, V2	OUTPUT	Doubler output
VEE	OUTPUT	-1.5V
T1, T2	INPUT	TEST pin
OO	OUTPUT	32KHz oscillator output
OI	INPUT	32KHz oscillator input
VDD	POWER	+1.5V power supply
GND	POWER	Ground
I0, I1, I2, I3, I4 and I5	INPUT(PL)	Input key
C[1:3]	OUTPUT	LCD Common output
S[1:10]	OUTPUT	LCD Segment output
PB	INPUT(PH)	RESET
O0, O1, O2 and O3	OUTPUT	Output Pin

Note: (PH) - pull high , (PL) – pull low.

**Absolute Maximum Ratings**

Supply voltage Vdd - Vss.....0 to 5V  
 Input voltage Vin.....Vss to Vdd  
 Operating temperature Top .....-10°C to 60°C  
 Storing temperature Tst .....-40°C to 70°C

**Comments**

Stress above those listed under Absolute Maximum Ratings may cause permanent damage to the device. These are stress rating only. Functional operation of this device at these or any other conditions above those indicated in the operational sections of this specification is not implied and exposure to absolute maximum rating conditions for extended periods may affect device reliability.

**D.C. Electrical Characteristics**

(GND = 0V, Vdd = 1.5V, Ta = 25°C unless otherwise specified)

Parameter	Symbol	Min.	Typ.	Max.	Unit	Conditions
Supply Voltage	Vdd	1.25	1.5	1.7	V	
Operating current	Idd	-	2	4	μA	No load
OSC. built-in cap	Cd	-	20	-	pF	
OSC. trimmer cap	Ctrim	5	-	35	pF	
Buzzer output current	IOH	6	-	-	MA	Vbd=0.0
Buzzer output current	IOL	6	-	-	MA	Vbd=1.5
LCD frequency	Flcd	-	64	-	Hz	
Segment current	Ilcd	0.15	-	-	μA	Vseg=0.2V
Common current	Icom	3.0	-	-	μA	Vcom=0.2V

**Pad Location**

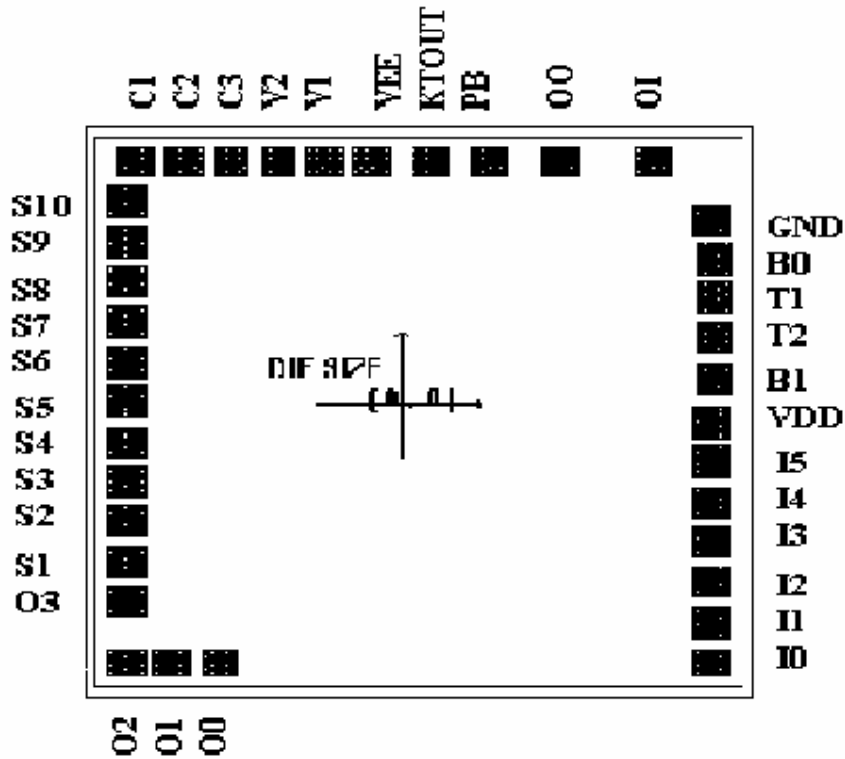

**Pad Coordinate**

PAD	X(μm)	Y(μm)	PAD	X(μm)	Y(μm)
O2	-1063.00	-909.50	VEE	-358.00	909.50
O1	-922.75	-909.50	KOUT	-123.50	909.50
O0	-731.25	-909.50	PB	20.25	909.50
O3	-1063.00	-703.50	OO	321.75	909.50
S1	-1063.00	-568.50	OI	874.75	909.50
S2	-1063.00	-433.50	GND	1062.75	717.00
S3	-1063.00	-298.50	BD[0]	945.25	547.50
S4	-1063.00	-163.50	T1	945.25	412.50
S5	-1063.00	-28.50	T2	945.25	277.50
S6	-1063.00	163.00	B[1]	945.25	142.50
S7	-1063.00	298.00	VDD	1062.75	-27.00
S8	-1063.00	433.00	I5	1062.75	-162.00
S9	-1063.00	568.00	I4	1062.75	-300.50
S10	-1063.00	703.00	I3	1062.75	-444.50
C1	-1033.00	909.50	I2	1062.75	-583.00
C2	-898.00	909.50	I1	1062.75	-727.00
C3	-763.00	909.50	I0	1062.75	-865.00
V2	-628.00	909.50			
V1	-493.00	909.50			

Application Circuit

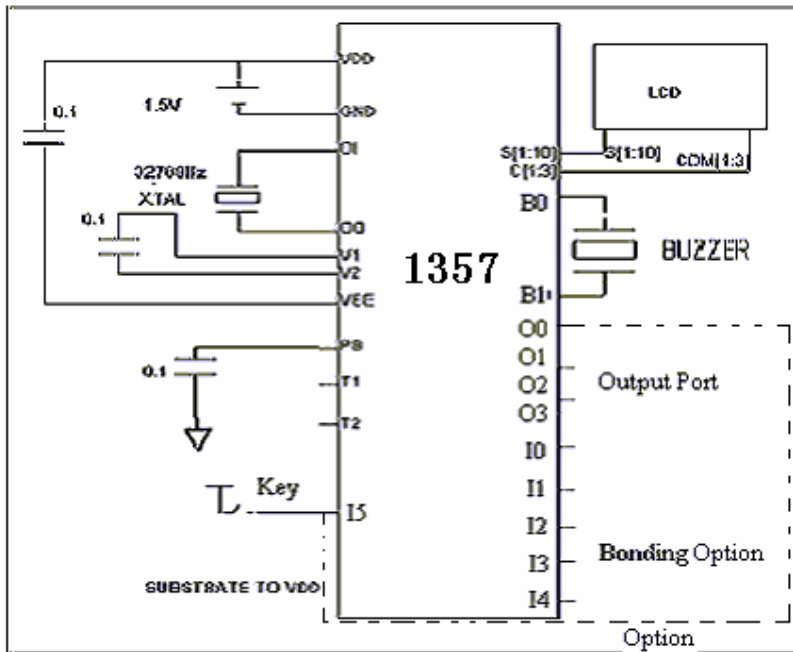

Key`s summary

	Press once	Press and hold 2 Second
I5(Key/Start/Stop)	Start/Stop	Reset default value

**Bonding option A (Range Selection)**

	Pin connection	Pin connection
I4 without resistance	VDD: Day / Hour Timer	GND: Hour / Minute Timer

**Bonding OptionB(Default Value)**

I3	I2	I1	I0	Default Value Day	Default Value Hour
GND	GND	GND	GND	1	1
GND	GND	GND	VDD	2	2
GND	GND	VDD	GND	3	3
GND	GND	VDD	VDD	4	4
GND	VDD	GND	GND	5	5
GND	VDD	GND	VDD	6	6
GND	VDD	VDD	GND	7	8
GND	VDD	VDD	VDD	14	10
VDD	GND	GND	GND	28	12
VDD	GND	GND	VDD	30	18
VDD	GND	VDD	GND	45	36
VDD	GND	VDD	VDD	60	60
VDD	VDD	GND	GND	70	70
VDD	VDD	GND	VDD	80	80
VDD	VDD	VDD	GND	90	90
VDD	VDD	VDD	VDD	99	24

**Output Waveform**

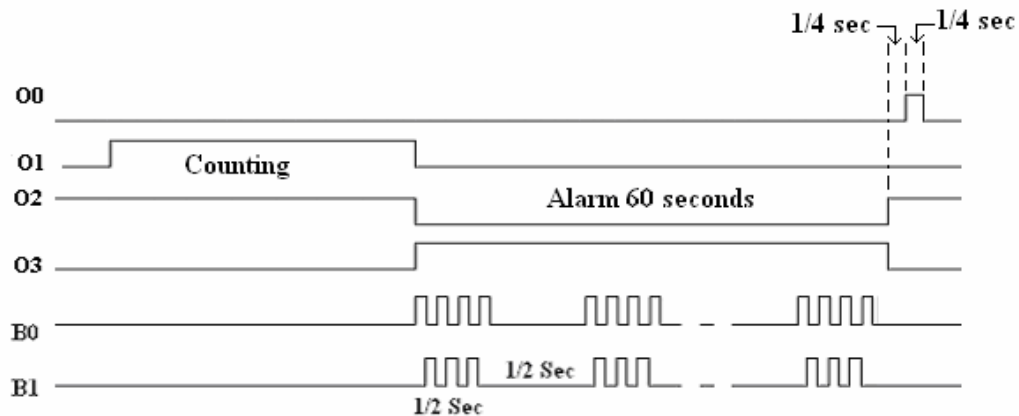

**LCD Drawing**

Pin 1 .....

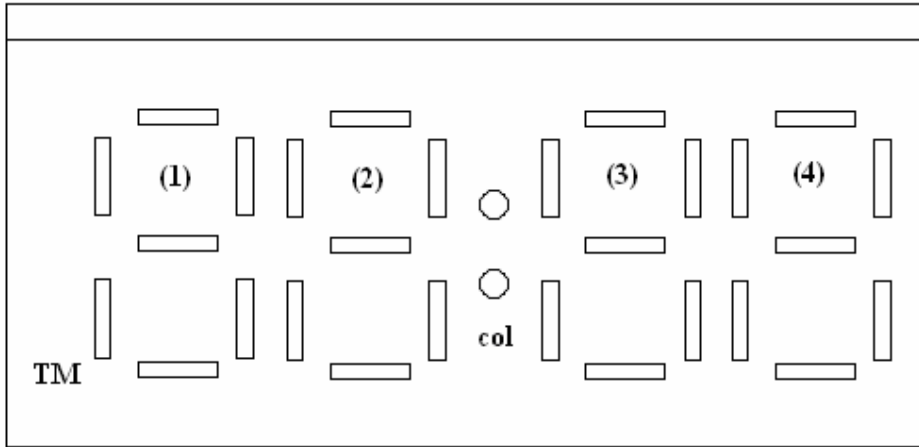

**LCD Table(LCD – 13XX)**

Pin Name	Pad	COM1	COM2	COM3		Pin Name	Pad	COM1	COM2	COM3
Pin 1	C3			COM3		Pin 8	S5	2b	2c	2d
Pin 2	C2		COM2			Pin 9	S6	3f	col	3e
Pin 3	C1	COM1				Pin 10	S7	3a	3g	3d
Pin 4	S1	1f	1e	TM		Pin 11	S8	3b	3c	4e
Pin 5	S2	1a	1g	1d		Pin 12	S9	4f	4g	4d
Pin 6	S3	2f	1b	1c		Pin 13	S10	4a	4b	4c
Pin 7	S4	2a	2g	2e						